

Part No.	75x50-D	75-D	100-D	125-D	150-D	200-D	300-D	400-D	
Size	mm	20x15	20	25	32	40	50	80	100
	inches	3/4x1/2	3/4		1 1/4	1 1/2	2	3	4
A		110	110		177	185		249	279
B		56	56		82	90		135	166
ØC		33	33		47	55		92.6	120
ØF		16.5	22		35	41		76	101
H		32	32		44	50		60	58
L		49	49		64	78		90	91

Units:mm

注意
400-Dのカムアームは4本です。

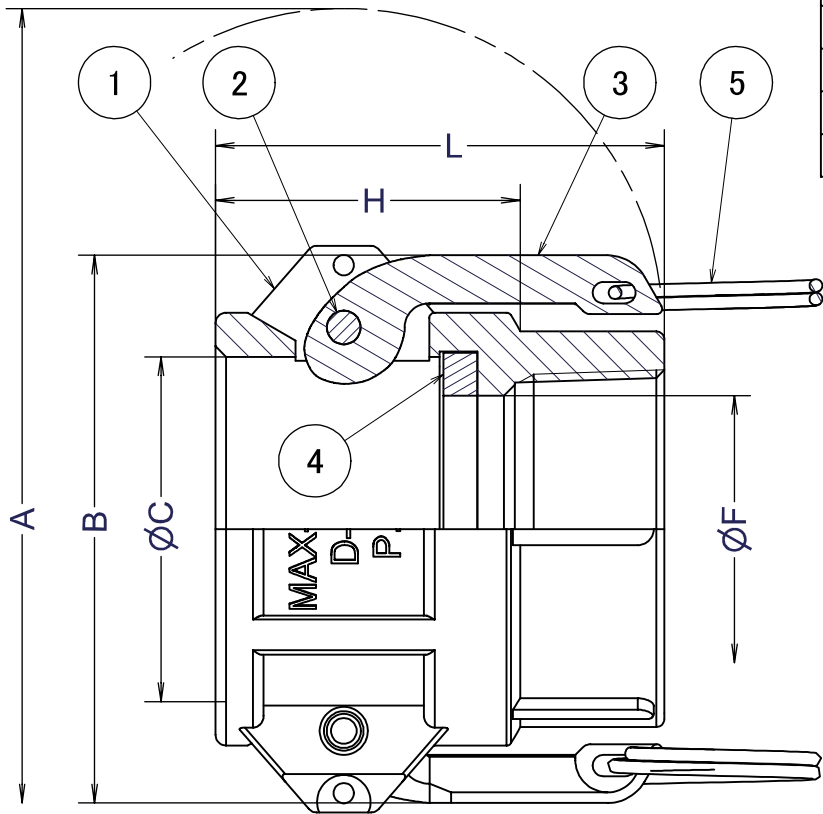

Section B-B

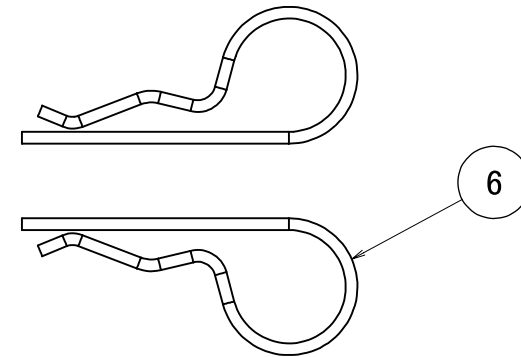
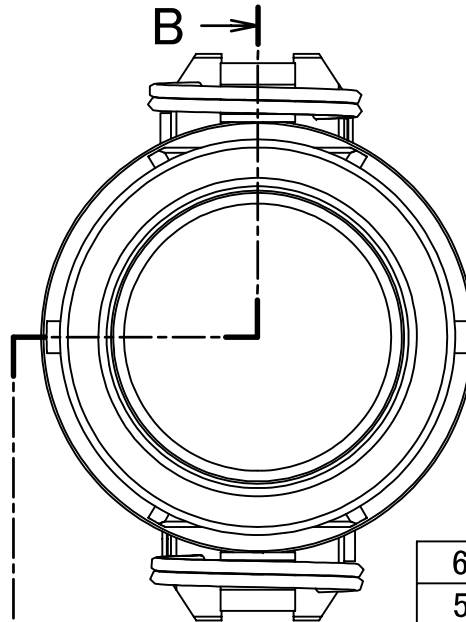

6	セーフティピン	SWRH77B	2	
5	リング	SUS430	2	
4	ガスケット	NBR	1	
3	カムアーム	SUS430	2	
2	ピン	SUS430	2	
1	ボディ	ポリプロピレン	1	
ITEM	PART NAME	MATERIAL	Q'TY	REMARKS

Nominal Dia	CUSTOMER				TITLE
Fluid.					MAX-LOK MAX-D 雌ネジカプラ
Press.	DATE	SCALE	DRAW	APPR	
Temp.	Mar.5'13	none	ToMo		 FULLNESS JAPAN CORPORATION.
Drawing History	MAX-D-05PP-01			3	