

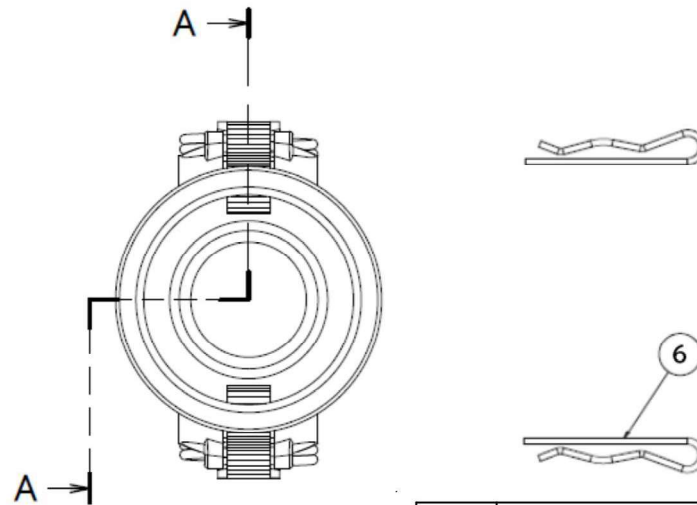

Part No.	75x50-C	75-C	100-C	125-C	150-C	200-C	300-C	400-C	
Size	mm	20x15	20	25	32	40	50	80	100
	inches	3/4x1/2	3/4	1	1 1/4	1 1/2	2	3	4
A									
B		54	54	61	84	91	101	120	
ØC		32.4	32.4	37.2	46	54.4	64	92.2	
ØF		8	14	19	23	30	40	63	
ØG		14	20.6	26.4	32.8	39.6	52.4	77	
I		42	54	58	67	72	83	111.7	
L		77	89	101	115	121	140	174	

Units:mm

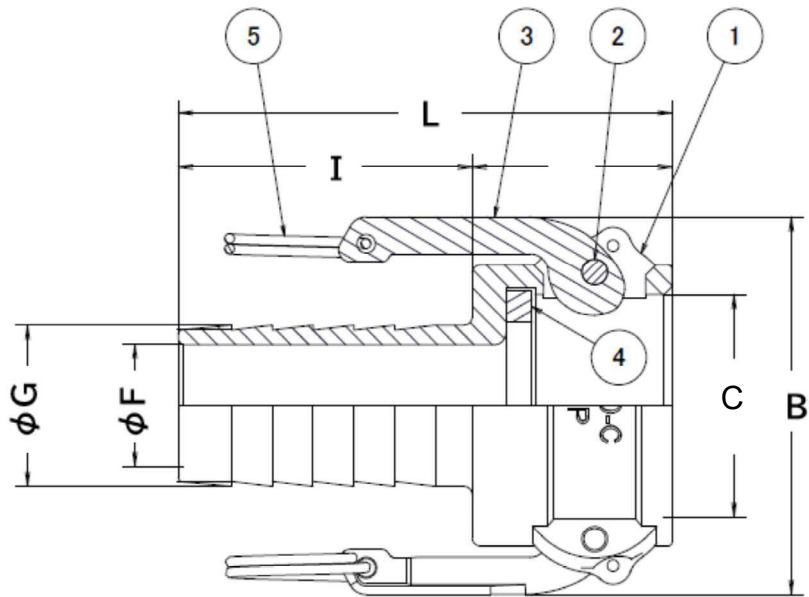

6	セーフティピン	SUS304	2	
5	リング	SUS304	2	
4	ガスケット	NBR	1	
3	カムアーム	SUS304	2	
2	ピン	SUS304	2	
1	ボディ	ポリプロピレン	1	
ITEM	PART NAME	MATERIAL	Q'TY	REMARKS

Nominal Dia		CUSTOMER				TITLE	
Fluid.						MAX-C-MB	
Press.		DATE	SCALE	DRAW	APPR	ホースシャンクカップラー	
Temp.		none					
Drawing History		DWG No.			3		
					 FULLNESS JAPAN CORPORATION.		

MAX-C-MB-05PP-N03

3

FULLNESS JAPAN CORPORATION.