

Part No.	75x50-E	75-E	100-E	125-E	150-E	200-E	250-E	300-E	400-E	
Size	mm	20x15	20	25	32	40	50	65	80	100
	inches	3/4x1/2	3/4	1	1 1/4	1 1/2	2	2 1/2	3	4
ØD	32	32	36.7	45.5	53.4	63	75.8	91.5	119.5	
ØF	8	14	18.5	25	31	43	55	67	91	
ØG <sub>1</sub>	14.7	20.6	27	33.9	39.9	52.8	65.1	77.7	103	
ØG <sub>2</sub>	12.7	18.6	25	31.8	37.7	50	62.5	74.5	100	
H	27	27	34	40	40	46	47	50	52	
I	42	65	59	61	75	87	88	98	124	
L	73	102	113	126	141	163	162	175	202	
Weight(kg)	0.14	0.2	0.31	0.54	0.71	1.09	1.42	1.96	3.49	

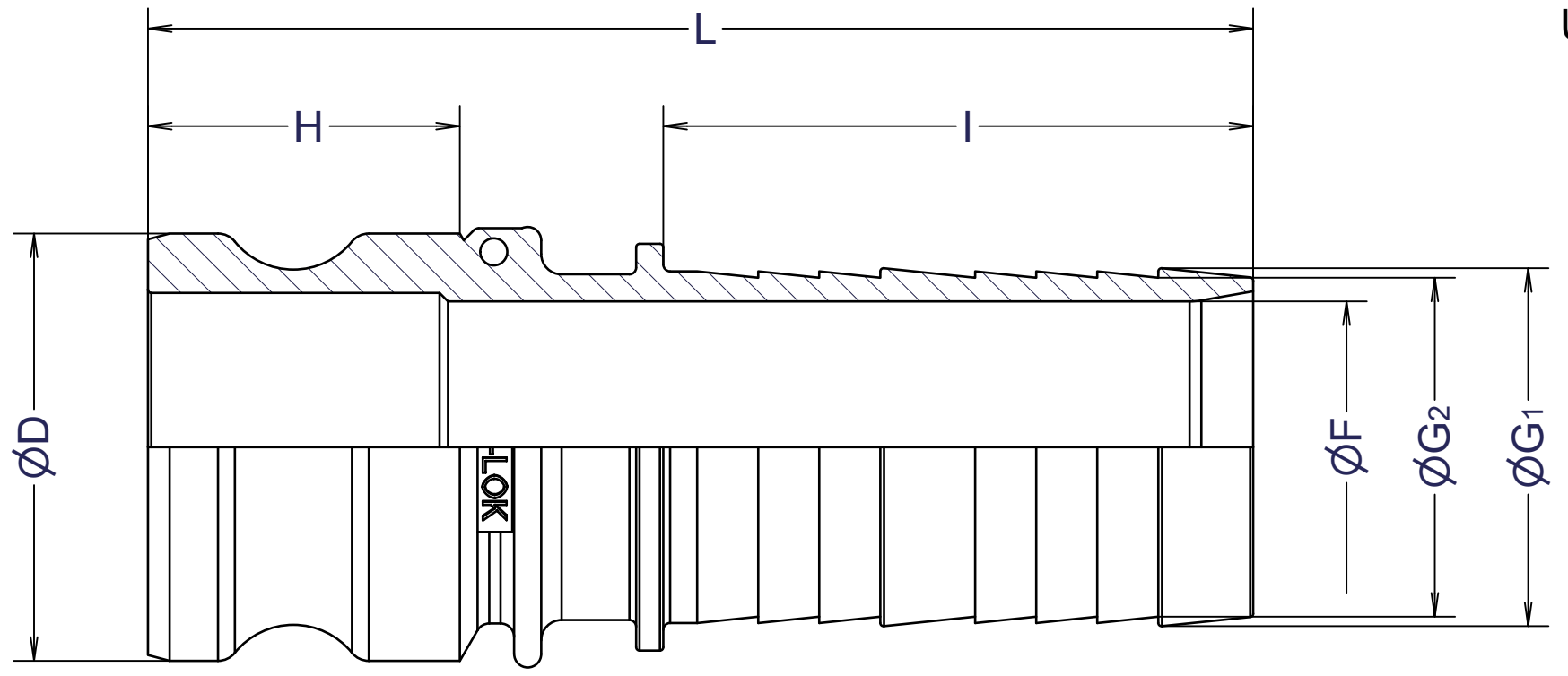
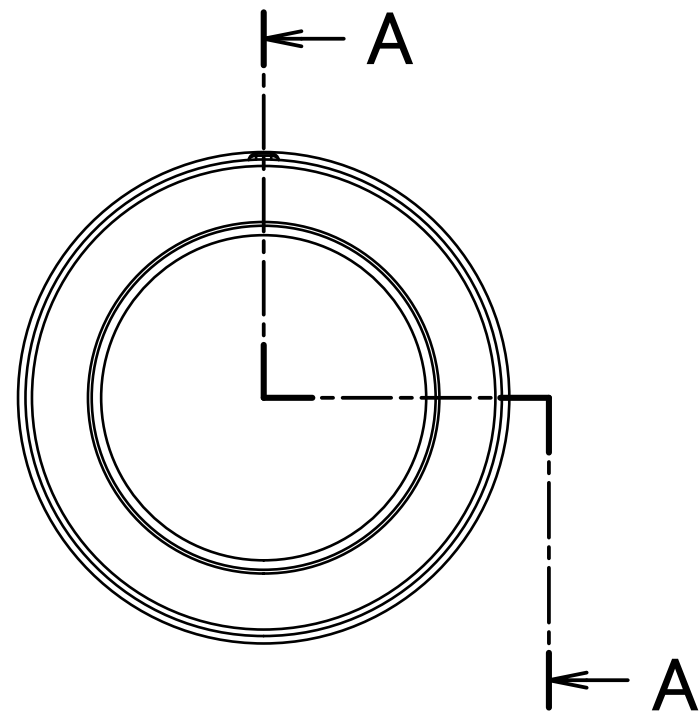

Units:mm

Section A-A

注意  
75x50-Eは、ボディとホースタケノコ  
の間の凸部はありません。

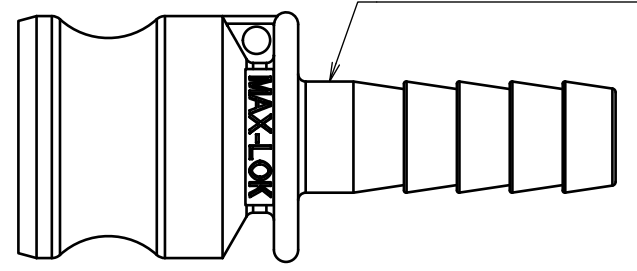

Nominal Dia	
Fluid.	
Press.	
Temp.	
Drawing History	

1	ボディ	SCS14A	1	
ITEM	PART NAME	MATERIAL	Q'TY	REMARKS
CUSTOMER		TITLE		
DATE		SCALE	DRAW	APPR
Oct.4'17		none	ToMo	
DWG No.		MAX-E-04SS-73 3		
		 MAX-E タケノコアダプター 