

Section E-E

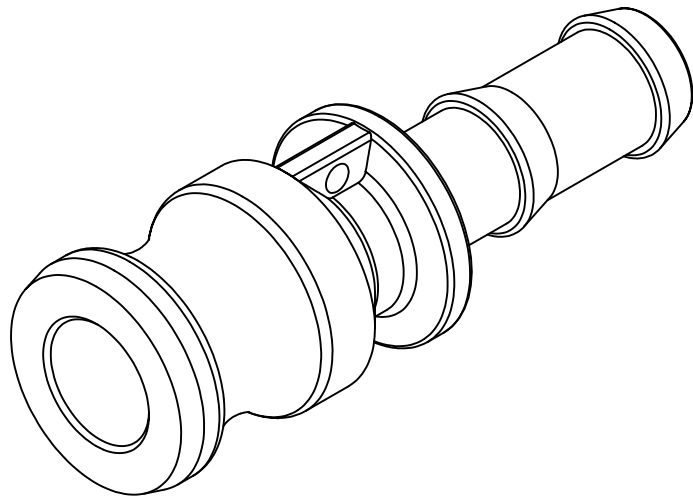

Nominal Dia		CUSTOMER				TITLE	<b>MAX-LOK</b>		
Fluid.		DATE				MAX-E-1/2"アダプター			
Press.		Aug.6'10	SCALE	2/1	DRAW	ToMo	DRAWN BY		
Temp.		DWG No.				FULLNESS JAPAN CORPORATION.			
Drawing History		MAX-E-15BS-01				3			

1	ボディ	BRASS	1	
ITEM	PART NAME	MATERIAL	Q'TY	REMARKS

