

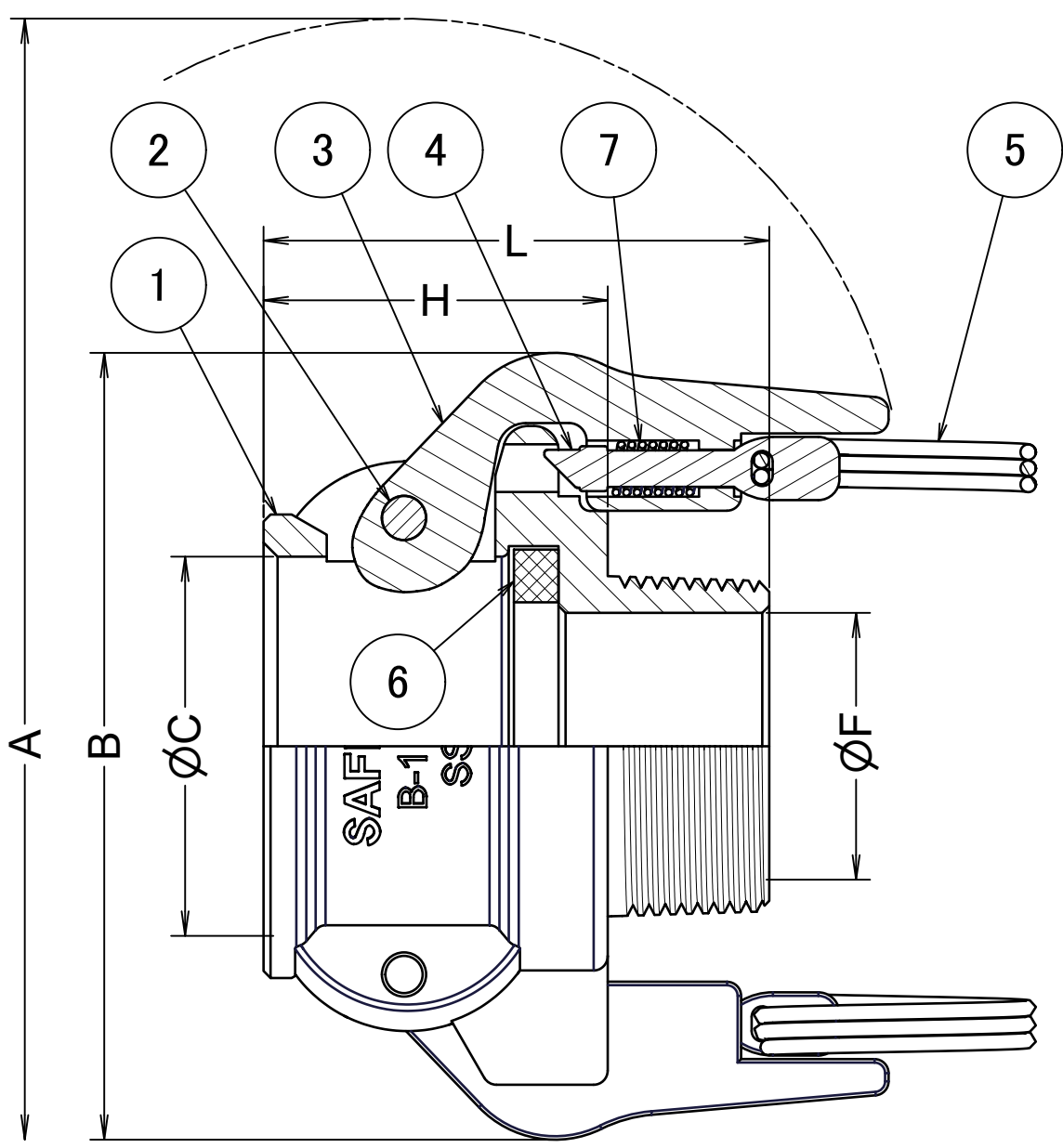

Item No.	B-1/2	B-3/4	B-1	B-1 1/4	B-1 1/2	B-2	B-2 1/2	B-3	B-4	
Size	mm	20x15	20	25	32	40	50	65	80	100
	inches	3/4x1/2	3/4	1	1 1/4	1 1/2	2	2 1/2	3	4
A	167	167	178	197	205	214	226	252	280	
B	83	83	91	105	113	122	134	154	182	
ØC	32.8	32.8	37.4	46	54	64	76.5	93	120.2	
ØF	14	19	25	32	38	50	60	76	96	
H	36	36	43	49	49	52	57	57	59	
L	54	56	64	73	72	78	90	89	97	
Weight(kg)	0.39	0.40	0.49	0.75	0.77	0.86	1.28	1.58	2.72	

Units:mm

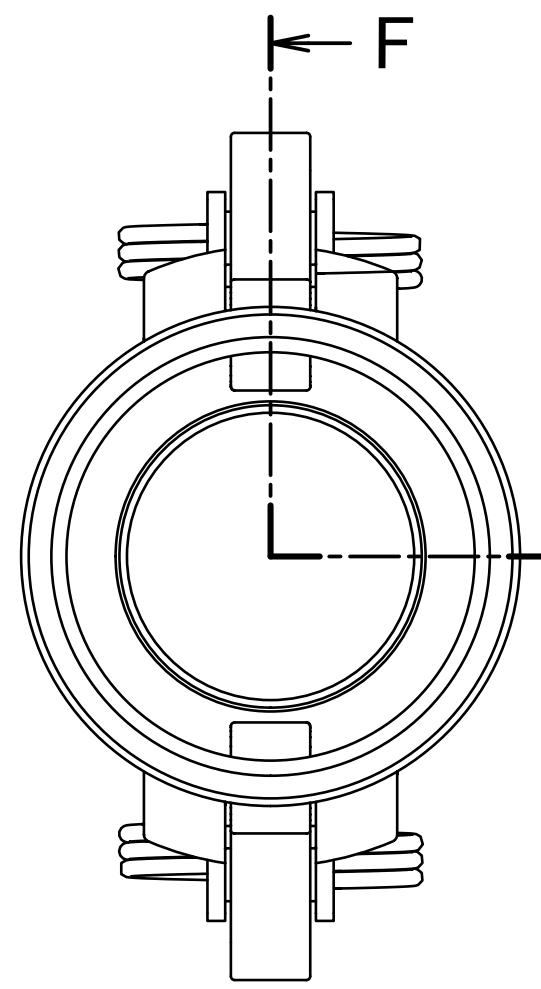

Section F-F

7	スプリング	SUS316	2	
6	ガスケット	NBR	1	
5	プル・リング	SUS316	2	
4	セーフティロッド	SUS316	2	
3	カムアーム	SCS14A	2	
2	ピン	SUS316	2	
1	ボディ	SCS14A	1	
ITEM	PART NAME	MATERIAL	Q'TY	REMARKS
CUSTOMER		TITLE		
		SAFLOK.jp		
		SAF-B 雄ネジカプラー		
DATE	SCALE	DRAW	APPR	
Jul.7'20	none	ToMo		
DWG No.				
SAF-B-04SS-01			3	
		 FULLNESS JAPAN CORPORATION.		