

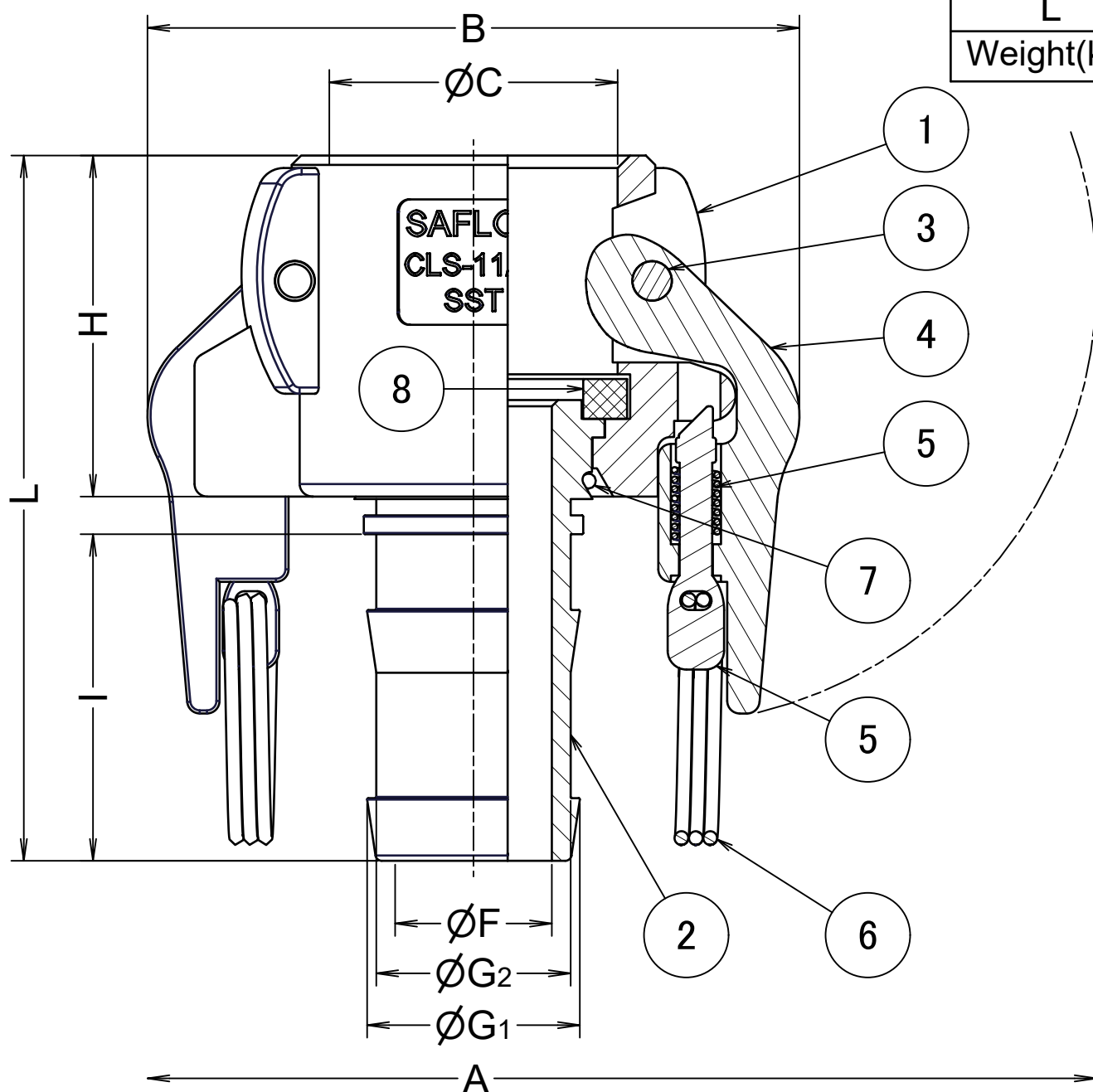

Item No.	CLS-3/4	CLS-1	CLS-1 1/4	CLS-1 1/2	CLS-2	CLS-2 1/2	CLS-3	CLS-4	
Size	mm	20	25	32	40	50	65	80	100
	inches	3/4	1	1 1/4	1 1/2	2	2 1/2	3	4
A	167	178	197	205	214	226	252	280	
B	83	91	105	113	122	134	154	182	
ØC	32.8	37.4	46	54	64	76.5	93	120.2	
ØF	14	20	25	32	42	56.5	67	89.5	
ØG ₁	21.6	27.4	34	40.7	53	67	78.7	104	
ØG ₂	18.5	25	31.2	37.4	50	63	75	100	
H	42	48	54	55	60	64	64	68	
I	46	53	52	68	80	75	95	102	
L	92	106	112	129	149	145	168	178	
Weight(kg)	0.48	0.62	0.93	1.03	1.35	1.6	2.47	4.27	

Units:mm



Section J-J

9	スプリング	SUS316	2	
8	ガスケット	NBR	1	
7	ストッパーリング	SUS316	1	
6	プル・リング	SUS316	2	
5	セーフティロッド	SUS316	2	
4	カムアーム	SCS14A	2	
3	ピン	SUS316	2	
2	ルーズシャンク	SCS14A	1	
1	ボディ	SCS14A	1	
ITEM	PART NAME	MATERIAL	Q'TY	REMARKS
CUSTOMER		TITLE		
		SAFLOK.jp		
		SAF-CLS ルーズシャンク型		
DATE	SCALE	DRAW	APPR	
Jul.8'20	none	ToMo		
DWG No.				
SAF-CLS-04SS-02			3	
		 FULLNESS JAPAN CORPORATION.		