

Part No.	F-1/2"	F-3/4"	F-1"	F-1 1/4"	F-1 1/2"	F-2"	F-2 1/2"	F-3"	F-4"	
Size	mm	20x15	20	25	32	40	50	65	80	100
	inches	3/4x1/2	3/4	1	1 1/4	1 1/2	2	2 1/2	3	4
ØD		32	32	36.7	45.4	53.4	63	75.7	91.5	119.5
ØE		14	20	23.7	28.5	36.5	47.4	56	73	98
K		35	35	40.5	48	59.5	68	84	100	129
H		27	27	34	40	42	47	50	51	52.5
I		21	21	22.5	25.5	26	30	33	36	42
L		59	59	73	82	84.5	94.5	102	106	123
Weight(kg)		0.22	0.17	0.31	0.54	0.66	0.85	1.56	1.8	3.17

Dimensions:mm

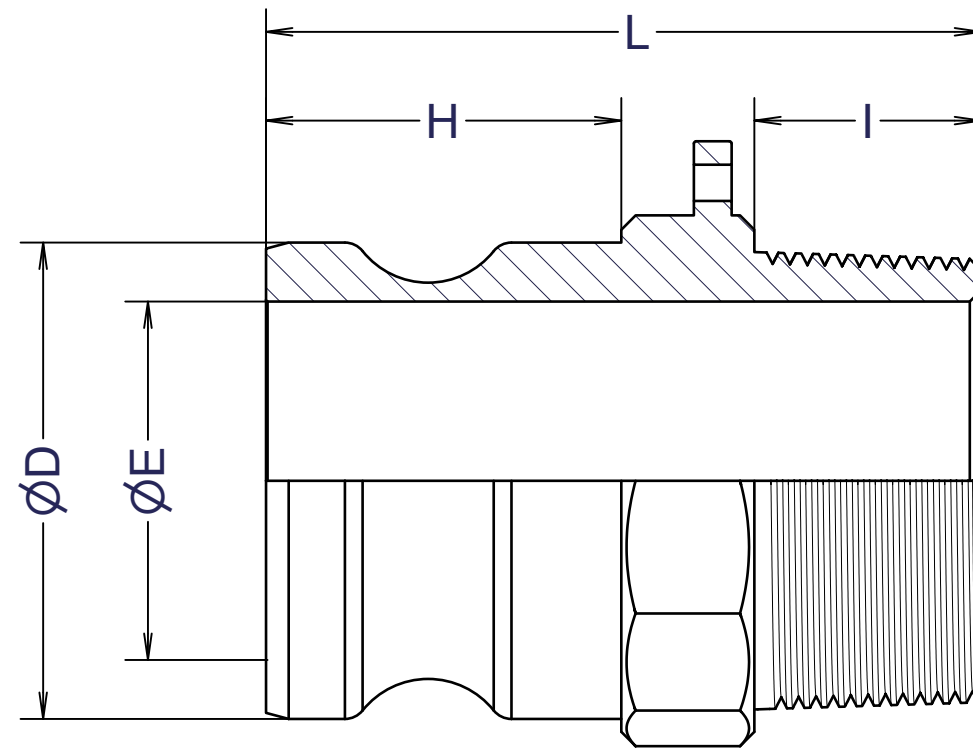
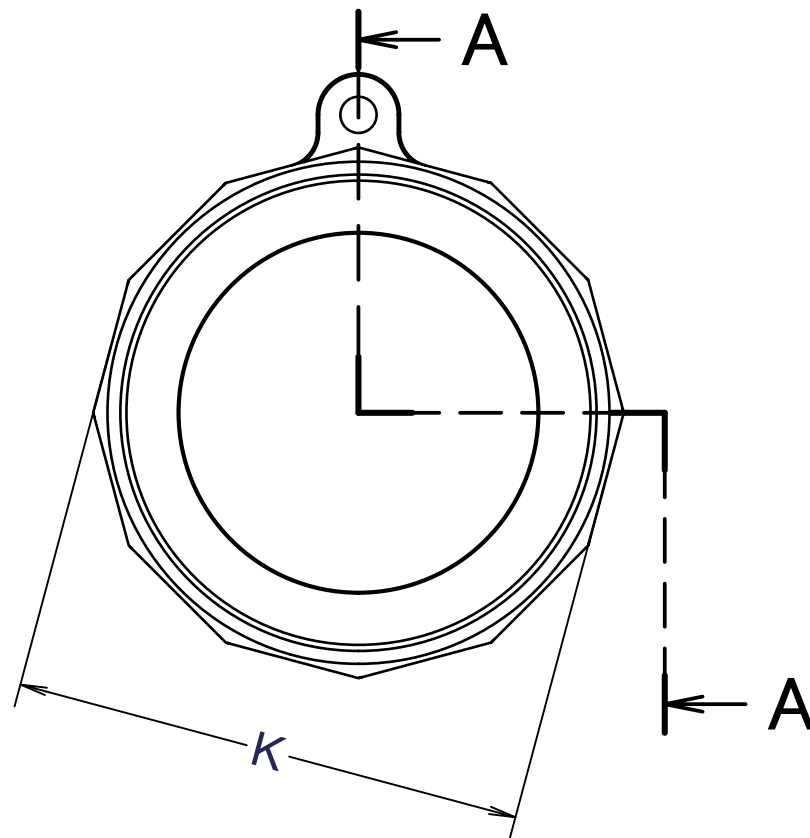

Section A-A

Nominal Dia	1 BODY				SCS14A	1	
	ITEM PART NAME				MATERIAL	Q'TY	REMARKS
	CUSTOMER				TITLE		
	DATE SCALE DRAW APPR				SAF-F 雄ネジアダプター		
	Temp.				TITLE		
Fluid.	Jul.11'08 none ToMo				SAFLOK Japan		
Press.	DWG No.				FULLNESS JAPAN CORPORATION.		
Temp.	SAF-F-04SS-01				3		
Drawing History							



FULLNESS JAPAN CORPORATION.