

Part No.	75-FA	100-FA	125-FA	150-FA	200-FA	250-FA	300-FA	400-FA	
Size	mm	20	25	32	40	50	65	80	100
	inches	3/4	1	1 1/4	1 1/2	2	2 1/2	3	4
$\phi D$	32	36.7	45.5	53.4	63	75.8	91.5	119.5	
$\phi E$	21	23.8	28.5	36	45.5	56.3	73	98	
P.C.D. $\phi F$	75	90	100	105	120	140	150	175	
$\phi G$	100	125	135	140	155	175	185	210	
$n$	4	4	4	4	4	4	8	8	
$\phi h$	15	19	19	19	19	19	19	19	
$T$	14	14	16	16	16	18	18	18	
$H$	27	32	37	37	45	47	48	52	
$L$	65	72	85	85	91	91	96	100	
Weight(kg)	0.85	1.40	1.85	2.09	2.67	3.54	4.04	5.34	

Units:mm

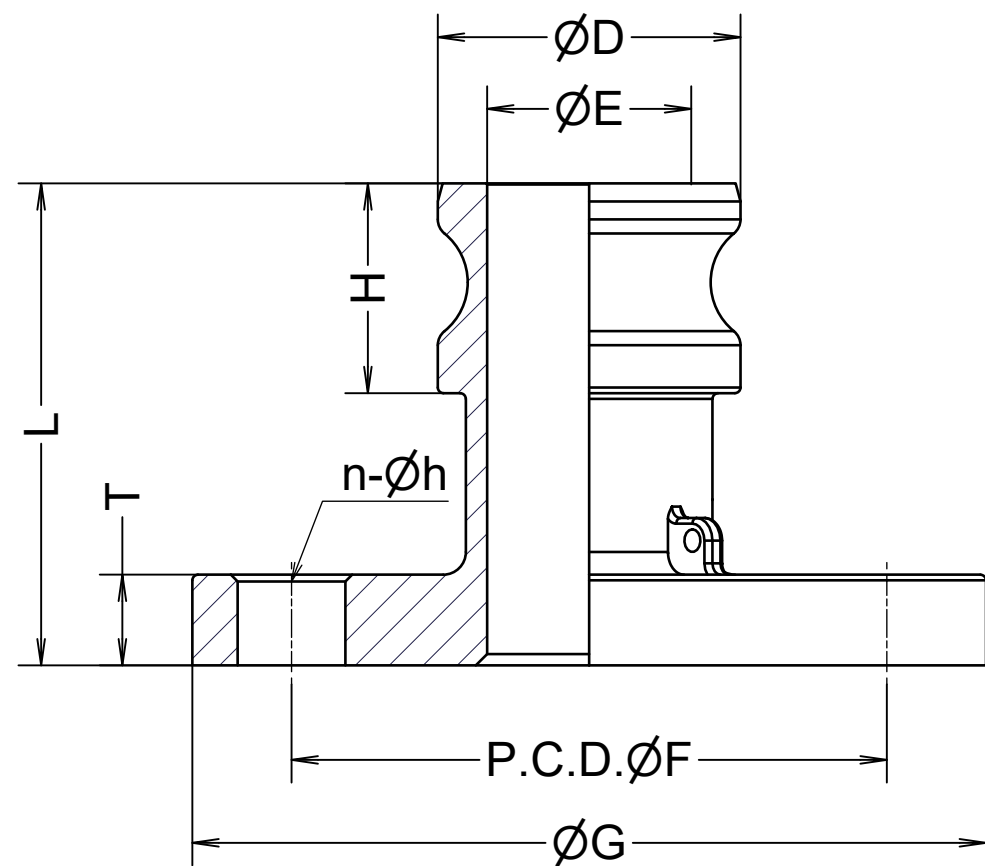
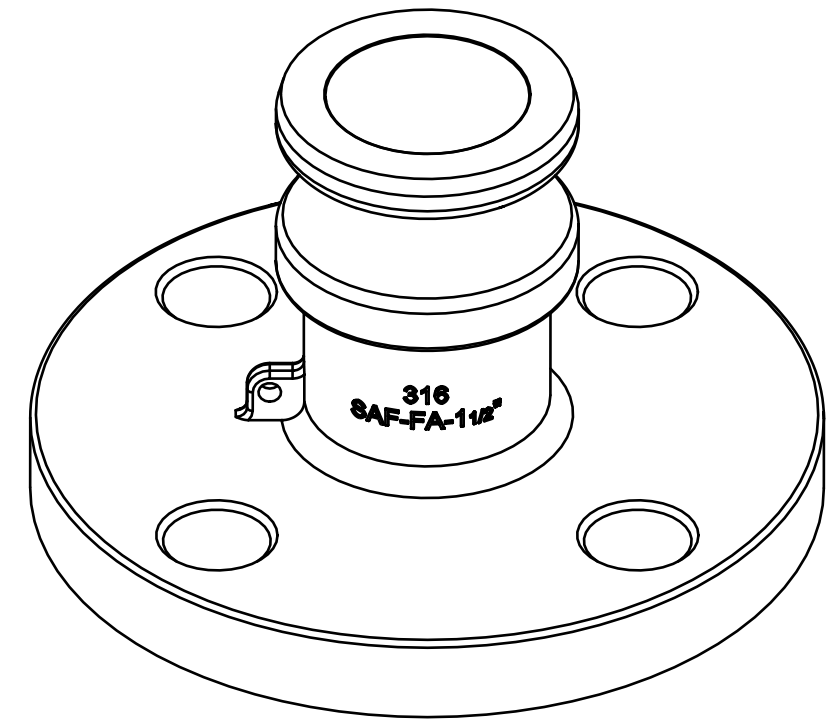

Section D-D

Nominal Dia	
Fluid.	
Press.	
Temp.	
Drawing History	

1	Body	SCS14A	1	SUS316
ITEM	PART NAME	MATERIAL	Q'TY	REMARKS
CUSTOMER		TITLE		
		SAFLOK.jp		
		SAF-FA フランジアダプター		
DATE		SCALE	DRAW	APPR
Oct.18'21		none	ToMo	
DWG No.		3		
SAF-FA-04SS-12		FULLNESS JAPAN CORPORATION.		

